



Cockpit Marine Diesel Tachometer 85mm

Tech Support 1-800-265-1818
http://usa.vdo.com

Instruction Sheet # 2910000084000

Rev 10-2020

Gauge Installation:

1. Select the desired mounting location of the instrument.
2. Depending on your mounting configuration, it might be necessary to program the gauge before installation.
3. Mount the gauge and secure with the included hardware. Tighten mounting nuts using 7mm or 9/32 wrench to 7inch lbs (finger tight plus 1/4 turn).

Wiring the Gauge:

1. Route wires from the instrument to:
 - (a) Battery (+) switched power after the fuse box or a user supplied in line 5A fuse to terminal "BAT".
 - (b) Light switch after the fuse box, or a user supplied in line 1A fuse after the switch to the light bulb.
 - (c) Ground location not shared with other electronics (such as battery negative terminal or ground bus bar) to terminal "GND" and the light bulb.
 - (d) Route the signal wire from the gauge (S/G) to the signal wire source location. This will be where the tachometer receives its signal from.

Terminal	Description
BAT	Switched power (12V)
S/G	Tachometer signal input
GND	Ground

Read these instructions thoroughly before installation. Do not deviate from assembly or wiring diagram. Always disconnect battery ground before making any electrical connections.

Parts List

Item	Description	Qty
1	85mm gauge	1
2	Clamp and hardware	1
3	Instruction sheet	1

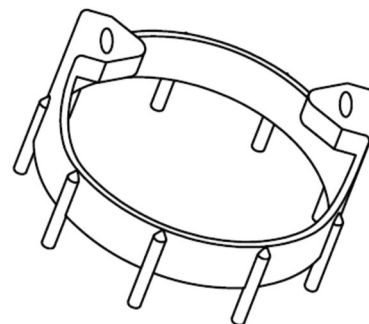
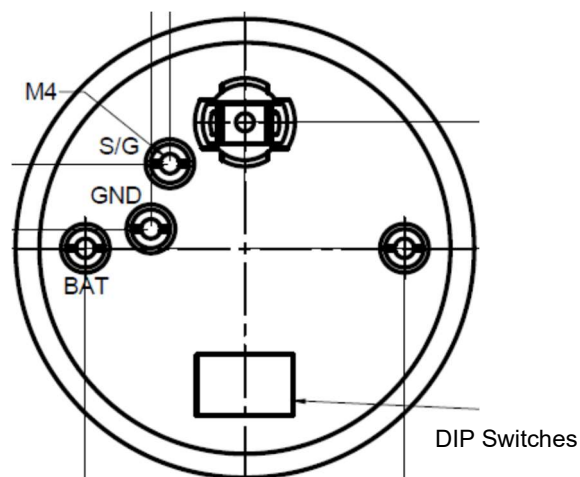

Merchandise warranted against defects in factory workmanship and materials for a period of 24 months after purchase. This warranty applies to the first retail purchaser and covers only those products exposed to normal use or service. Provisions of this warranty shall not apply to a VDO product used for a purpose for which it is not designed, or which has been altered in any way that would be detrimental to the performance or life of the products, or misapplication, misuse, negligence or accident. On any VDO part or VDO product found to be defective after examination by manufacturer, manufacturer will only repair or replace the merchandise through the original selling dealer. Manufacturer assumes no responsibility for diagnosis, removal and/or installation labor, loss of vehicle use, loss of time, inconvenience or any other consequential expenses. The warranties herein are in lieu of any other expressed or implied warranties, including any implied warranty or merchantability of fitness, and any other obligation on the part of manufacturer, or selling dealer.

Cockpit Marine Diesel Tachometer 85mm

Tech Support 1-800-265-1818
<http://usa.vdo.com>

Instruction Sheet # 2910000084000

Rev 10-2020

Programming the gauge:

The picture below shows the settings for the dip switches on/off

Dip switches located on back of gauge

	1	2	3	4	5	6
On	On	On	On	On	On	On
Off	Off	Off	Off	Off	Off	Off

Common Settings

Signal from alternator "W" terminal

- 4 poles #1 on, all others off
- 6 poles #2 on, all others off
- 8 poles #3 on, all others off
- 10 poles #4 on, all others off
- 12 poles #5 on, all others off

Signal from generator sender

- 4 pulse/rev sender
 - 1/2:1 Ratio #1 on, all others off
 - 1:1 Ratio #2 on, all others off (*VDO 340-001*)
 - 1:2 Ratio #3 on, all others off
- 8 pulse/rev sender
 - 1:2 Ratio #4 on, all others off
- 16 pulse/rev sender
 - 1:2 Ratio #5 on, all others off

If you are unsure of you're the number of poles in your alternator or the pulses from your generator sender, you can select the required Dip Switch by referencing your output signal frequency and the associated reference RPM (obtainable by using an oscilloscope at a marina or similar service center).

Dip Switch

	1	2	3	4	5
1000	33	67	133	267	533
2000	67	133	267	533	1067
3000	100	200	400	800	1600
4000	133	267	533	1067	2133

Signal Frequency in Hz

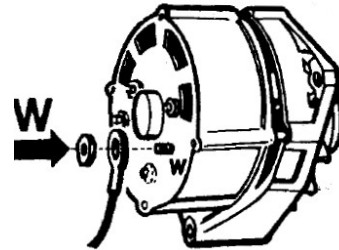

Alternator input

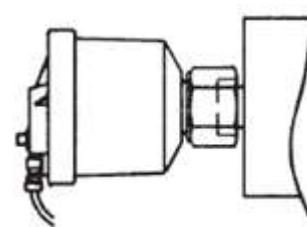

Pulse generator driven by camshaft