



## Cockpit AutoChoice 2 1/16" (52mm) Gauges

Tech Support 1-800-265-1818  
http://usa.vdo.com

Instruction Sheet # 2910002307400

Rev 09-2019

### Installation: All Cockpit AutoChoice Gauges

1. Select the desired mounting location of the instrument. Cut a 2 1/16" opening if required, making sure there is enough clearance behind the panel for light bulb socket, wires and any tubing needed (see below)
2. Mount the gauge and secure with the supplied clamp and nuts.

### Installation: Electrical Gauges

1. Route wires from the instrument to:
  - (a) The light switch after the fuse box or user supplied in-line fuse rated at 1 amp to the light bulb
  - (b) A ground location isolated from other electronics
  - (c) +12V power source energized when the ignition switch is 'on' to the "B" terminal on the gauge
  - (d) The engine sensor to the "I" terminal on the gauge.

### Electrical Hookup:

I	Sender wire connection (Not used on Voltmeter)
↓	Ground (-)
B	Battery/Switched Power (+ 12V)

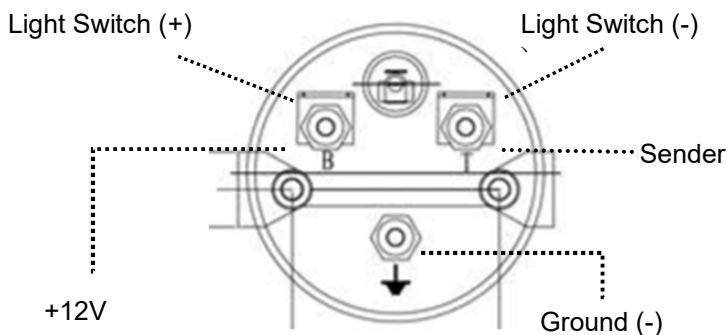

### Parts List

Item	Description	Qty
1	2 1/16 in (52mm) Gauge	1
2	Clamp	1
3	Instruction Sheet	1

Read these instructions thoroughly before installation. Do not deviate from assembly or wiring diagram. Always disconnect battery ground before making any electrical connections.

**IMPORTANT:** Mounting dimensions vary for different gauges. Please be certain to follow the instructions for your specific gauge.

Merchandise warranted against defects in factory workmanship and materials for a period of 24 months after purchase. This warranty applies to the first retail purchaser and covers only those products exposed to normal use or service. Provisions of this warranty shall not apply to a VDO product used for a purpose for which it is not designed, or which has been altered in any way that would be detrimental to the performance or life of the products, or misapplication, misuse, negligence or accident. On any VDO part or VDO product found to be defective after examination by manufacturer, manufacturer will only repair or replace the merchandise through the original selling dealer. Manufacturer assumes no responsibility for diagnosis, removal and/or installation labor, loss of vehicle use, loss of time, inconvenience or any other consequential expenses. The warranties herein are in lieu of any other expressed or implied warranties, including any implied warranty or merchantability of fitness, and any other obligation on the part of manufacturer, or selling dealer.

## Cockpit AutoChoice 2 1/16" (52mm) Gauges

Tech Support 1-800-265-1818  
<http://usa.vdo.com>

Instruction Sheet # 2910002307400

Rev 09-2019

### Installation: Mechanical Pressure Gauge

1. Route wires from the instrument to:
  - (a) The light switch after the fuse box or user supplied in-line fuse rated at 1 amp to the light bulb.
  - (b) Route oil supply tubing from engine to the back of the gauge. Coil and secure any excess capillary tube away from heat and moving parts. **WARNING:** only use tubing rated for use with engine oil, and rated for a minimum of 100psi (such as VDO 150-851 tubing kit)
  - (c) Use a rubber grommet in the firewall opening to prevent sharp edges from damaging the tubing where it passes through.

+12V and Ground from light switch to light bulb

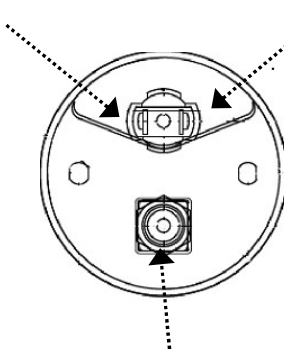

Tubing attachment 1/8-27 NPT threads

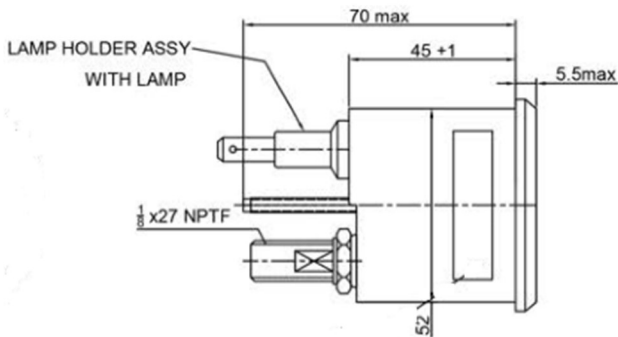

### Installation: Mechanical Temperature Gauge

1. Route wires from the instrument to:
  - (a) The light switch after the fuse box or user supplied in-line fuse rated at 1 amp to the light bulb.
  - (b) Route capillary tube and temperature probe to the engine: Coil and secure any excess capillary tube away from heat and moving parts.
  - (c) Use a rubber grommet in the firewall opening to prevent sharp edges from damaging the capillary tube where the capillary passes through.



#### **WARNING: DO NOT CUT THE BRAIDED STAINLESS STEEL CAPILLARY TUBE!**

The capillary tube is filled with an inert gas that is used to operate the gauge. If the gas is allowed to escape, it **will render the gauge inoperable. The tube cannot be repaired or refilled if damaged.**

+12V and Ground from light switch to light bulb

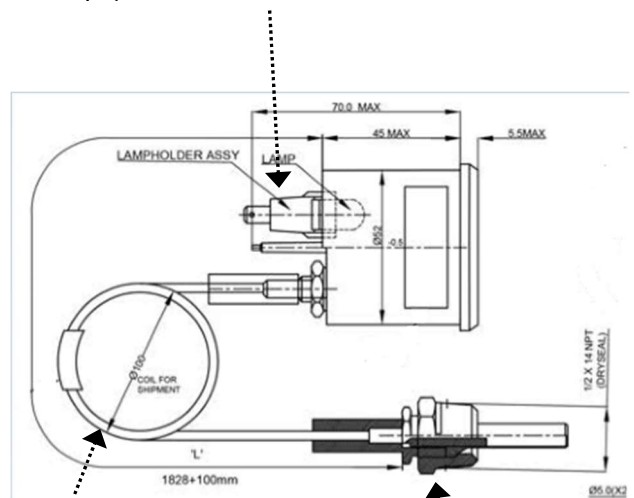

Do not cut this tube!

Temperature probe to engine